

**INSTALLATION INSTRUCTIONS:  
2018+ HARLEY-DAVIDSON SOFTAIL  
STAINLESS SUPERSPORT 2-1  
PART# 27337**

Congratulations, you have purchased the finest exhaust system available for your motorcycle. Your Vance & Hines exhaust is designed and crafted for performance, quality, and style. Please follow the instructions below, check exhaust system for missing or damaged parts and if you need any assistance please contact our technical support line (562) 921-7461.

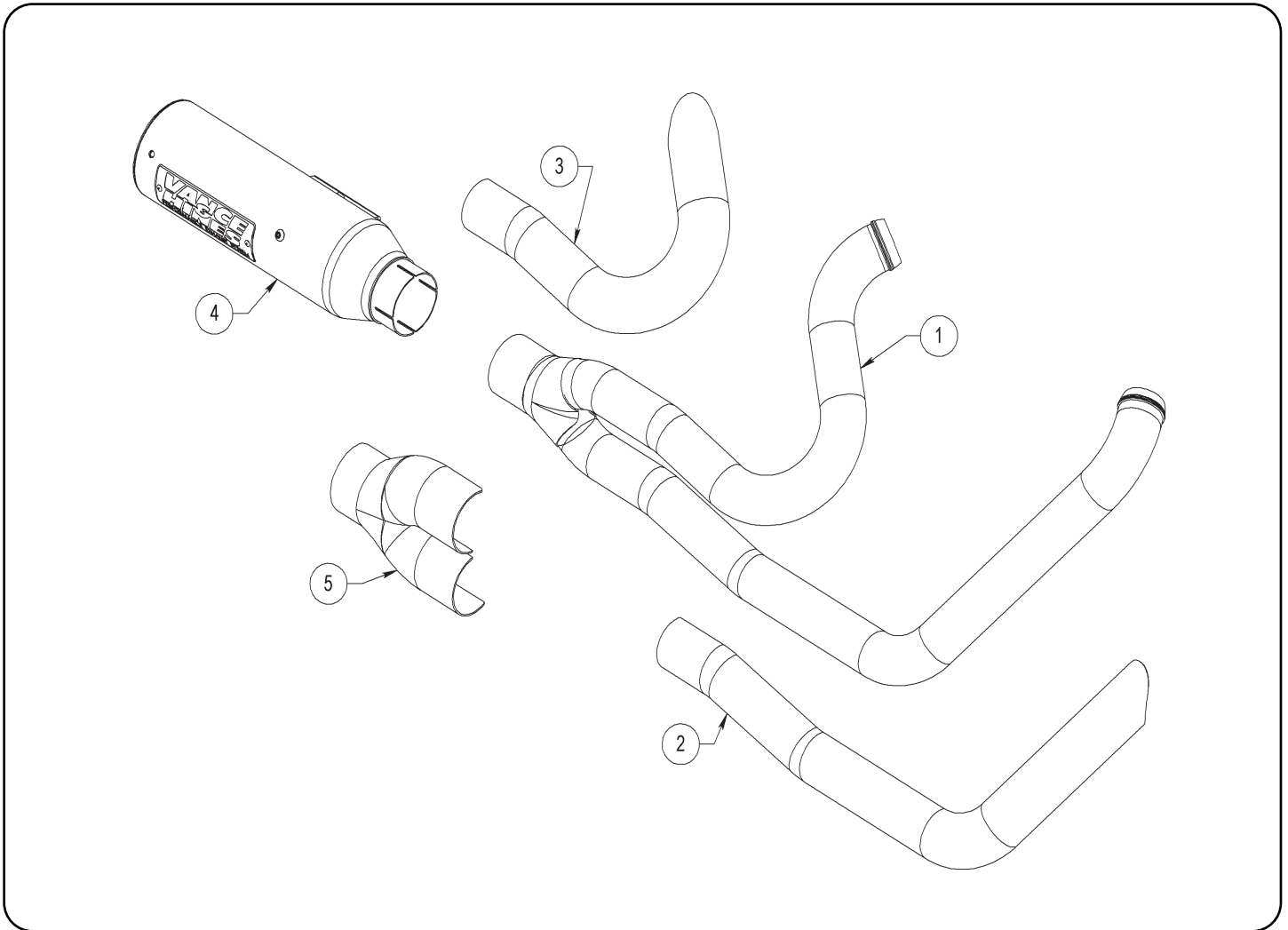

**PARTS LIST**

NO.	PART #	Description	Qty	NO.	PART #	Description	Qty
1	D1130FB	HEADER ASSEMBLY	1	11	A302HW	HHCS 3/8"-16 X 1.25"	2
2	D1132HB	FRONT HEAT SHIELD	1	12	A337HW	2.625 DIAMETER CLAMP	1
3	D1133HB	REAR HEAT SHIELD	1	13	A644ST	18-12MM O2 ADAPTER	2
4	D1130RB-S	MUFFLER ASSEMBLY	1	14	A739HW	BHCS 5/16"-24 X 1.25"	1
5	D137HB	COLLECTOR HEAT SHIELD	1	15	A740ST-P	SPACER 1-1/4 X 1/2	2
6	1103-P	BRACKET SPACER	2	16	A745HW-P	MID CONTROL SPACER	1
7	1200-P	MOUNTING BRACKET	1	17	A826HW	SHCS 3/8"-16 X 2-1/4"	2
8	A195HW	DOGBONE NUT PLATE	1				
9	A240HW	HHCS 5/16"-18 X 5/8"	2				

## HARDWARE

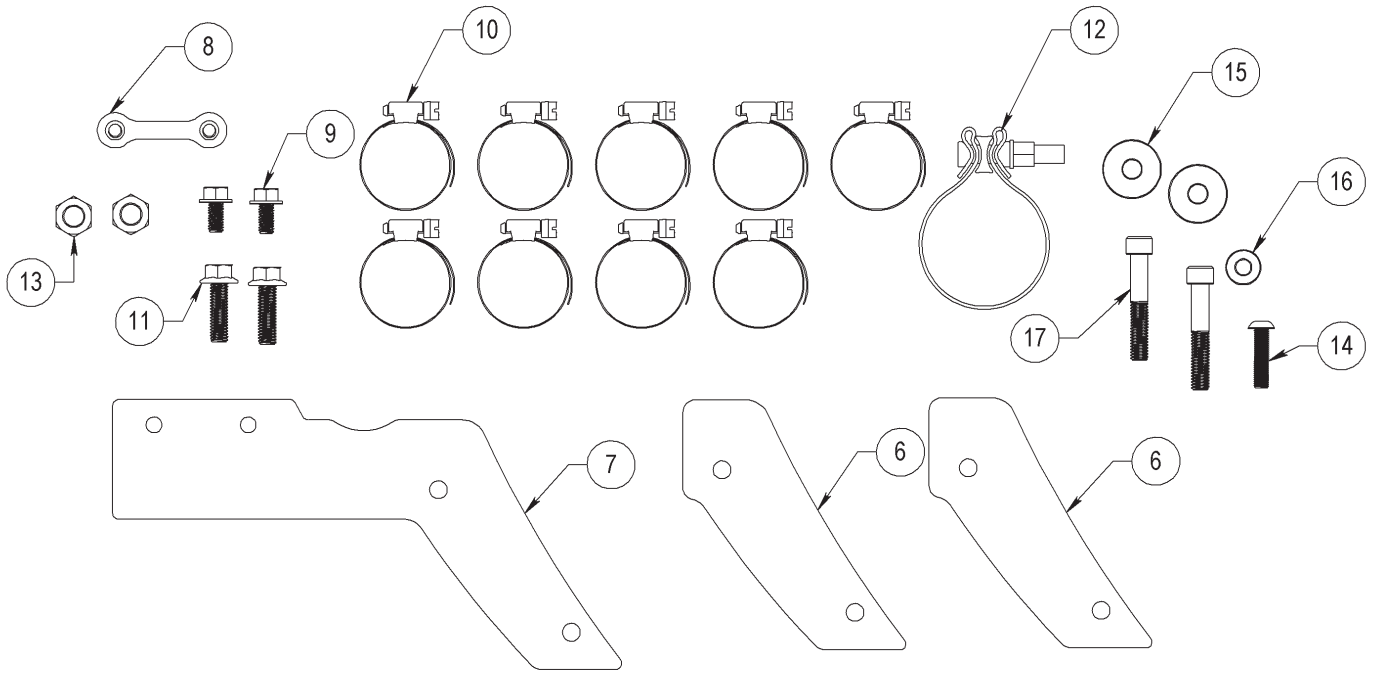

## TOOLS REQUIRED

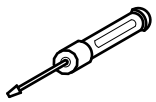

**Flat Head Screwdriver**

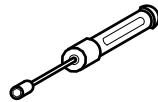

**5/16 Nut Driver**

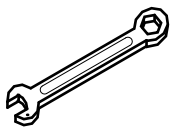

**Combination Wrenches:**  
1/2", 9/16", 14mm,  
17mm, 19mm

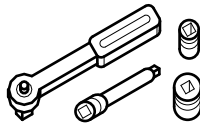

**3/8" Drive Ratchet w/ 4" extension**  
1/2", 9/16" Deep, 16mm Deep  
17mm Deep Sockets. T45 Torx Bit.

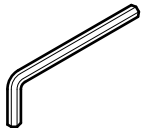

**Allen Wrenches:**  
5/32", 3/16", 5/16"

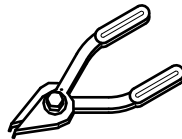

**Snap Ring Pliers**

## STOCK EXHAUST SYSTEM REMOVAL

1. Locate the rear O2 sensor connector. Remove the two bolts holding the right-side cover in place and gently pull cover off bike. NOTE: Pay attention to the wire routing for re-installation.
2. Locate the front O2 sensor connector. Unplug the sensor and feed the end of the wire through the frame, freeing it from the motorcycle.
3. On Floor board models, loosen the right-hand floor board mounting bolts to gain clearance for the exhaust removal and installation.
4. On Mid Mount models, remove the forward brake rod bolt and remove the mid mount foot peg bracket.
5. Loosen the heat shield clamps on both the front and rear exhaust pipes.
6. Remove the two mounting nuts from each head pipe, located at the cylinder head.
7. Remove the bolts attaching the mufflers to the mounting bracket.
8. Remove the entire exhaust system and set it aside.
9. If equipped remove passenger peg from stock mounting bracket. Save for re-use.
10. Remove the stock mounting bracket.
11. Carefully remove the exhaust port flanges and circlips from the stock exhaust system using the snap ring pliers. NOTE: Replace bent or damaged circlips.
12. Carefully remove the O2 sensors from the stock head pipes and save for re-use with the new system.
13. Check the condition of the exhaust gasket and replace if worn or damaged. Harley-Davidson part number 65324-83B.

## VANCE & HINES EXHAUST INSTALLATION

**NOTE: Saddlebag models (Low Rider ST, Sport Glide, Heritage) require separate purchase of VH Part# 21946 – Saddlebag Support Bracket.**

1. Install the supplied mounting bracket, 1200-P. Using the supplied hardware 3/8-16 x 1-1/4" flange bolt. Place two bracket spacers 1103-P in between the frame and the 1200-P bracket. Torque the mounting bracket bolts to 30-33 Ft.Lbs. Note: When installing VH Saddlebag support bracket or Burly Brand Brawler Kit, remove one bracket spacer (1103-P) When installing both, remove two bracket spacers (1103-P). **(Figure 1)**
2. Remove head pipe from protective packaging
3. Remove heat shields from their protective packaging. Place each heat shield on a non-abrasive surface such as a blanket or carpet. Use a felt tip pen and lightly mark the outside edge of each heat shield to show location of mounting clips where hose clamps will loop through.
4. Lay header assembly into front and rear heat shields and loosely install the #24 hose clamps (supplied) into mounting clips. Screw heads should be accessible when the system is installed on motorcycle for adjustment purposes. **(Figure 2)**
5. Apply a small amount of anti-seize compound to the threads of the oxygen sensors and install supplied 18mm to 12mm oxygen sensor adapter then install 12mm oxygen sensors. NOTE: Be careful not to get anti-seize on sensor tip, as it may affect sensor function.
6. Install flanges and circlips from stock system onto the new header pipes.
7. Using stock flange nuts, carefully install the header assembly onto the motorcycle. NOTE: Finger tighten only at this time.
8. Install torca band clamp with bolt facing down (supplied) onto the end of the muffler body **(Figure 2)**.
9. Install muffler assembly onto rear of header assembly.
10. Slide the nut plate (supplied) into the bracket that is welded to the back side of the muffler. Loosely install two 5/16" flange head bolts (supplied) through the 1200-P bracket onto the nut plate.
11. Install the collector heat shield onto the header by sliding it from the rear. Attach collector heat shield with two #24 hose clamps. Do not fully tighten. NOTE: Collector heat shield will go over head pipe heat shields. **(Figure 3)**
12. Tighten the exhaust port flange nuts, muffler mounting bolts, and tighten the torca band clamp.
13. Tighten hose clamps securing header heat shields and collector heat shield making sure that they stay aligned.
14. Route O2 sensor wires away from hot areas of the motorcycle. Plug the O2 sensor wires back into the wiring harness.
15. Re-install right side cover.
16. On floor-board and forward control models, tighten the floor board mounting bolts to OEM torque specifications.
17. On mid-mount models, re-install mid-mount foot peg with spacers (A740ST-P) and bolts (A826HW). Additionally, place spacer (A745HW-P) in between the brake rod and lever. Fasten with the supplied button head cap screw, A739HW **(Figure 4)**
18. For models with passenger foot peg attached to the stock exhaust bracket, re-install the left and right-side passenger foot pegs into the upper mounting holes **(Figure 5)**
19. Be sure to tighten all hardware before starting your motorcycle. After installation and before starting the motorcycle, completely clean pipes and mufflers a soft cloth and cleaning solvent that will leave no residue (glass cleaner, alcohol, acetone, etc...).

**FIGURE 1**

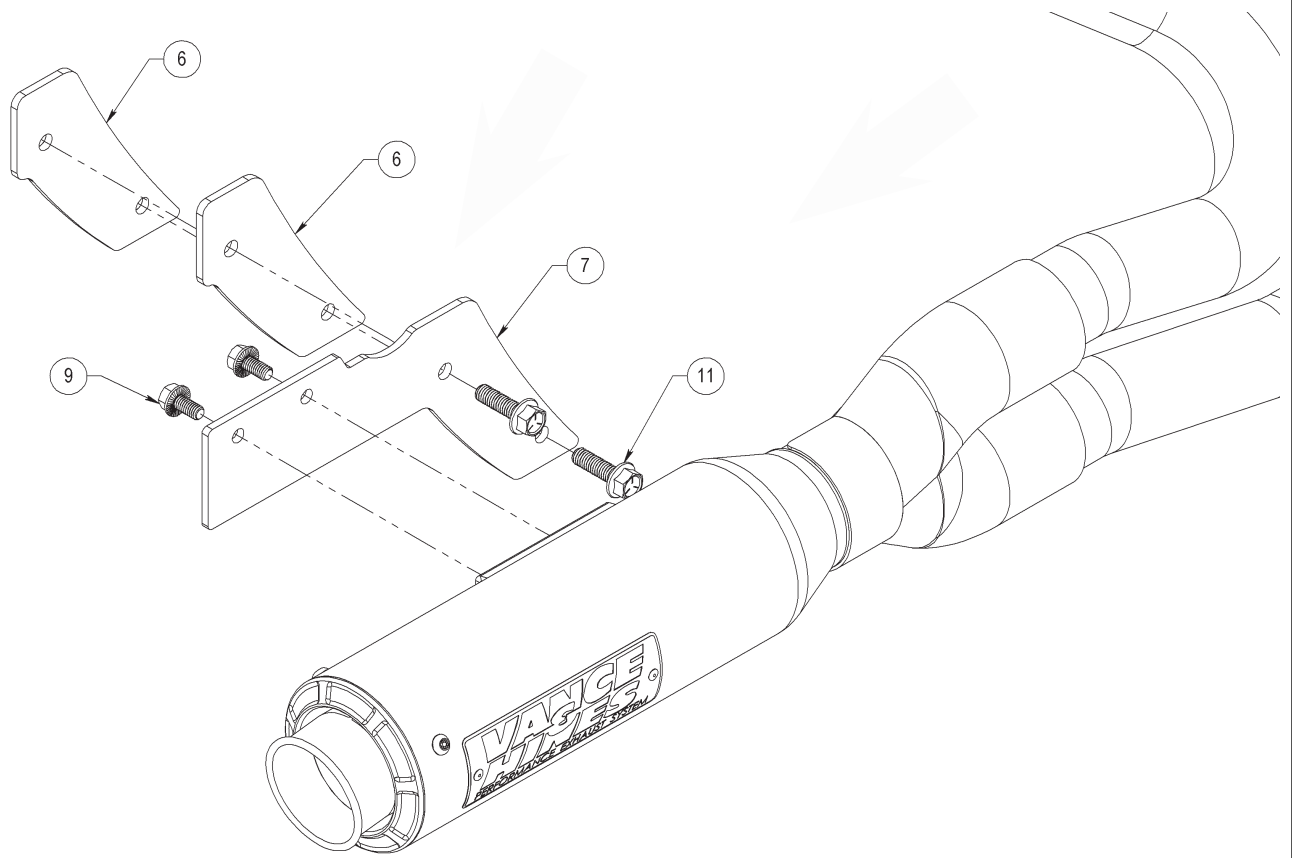

**FIGURE 2**

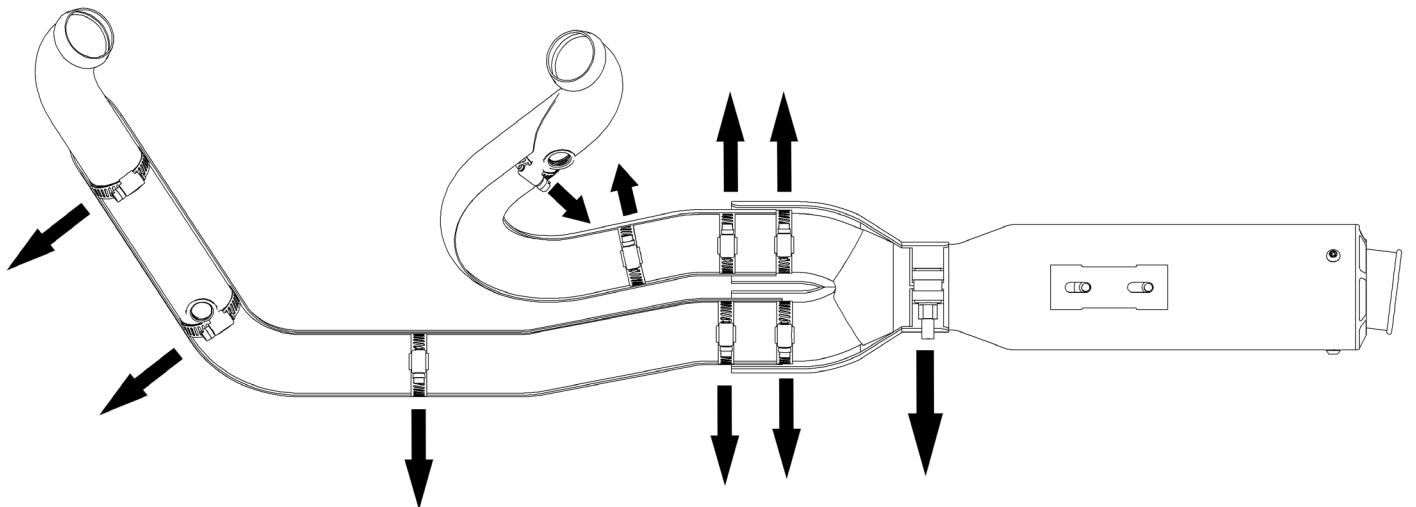

**FIGURE 3**

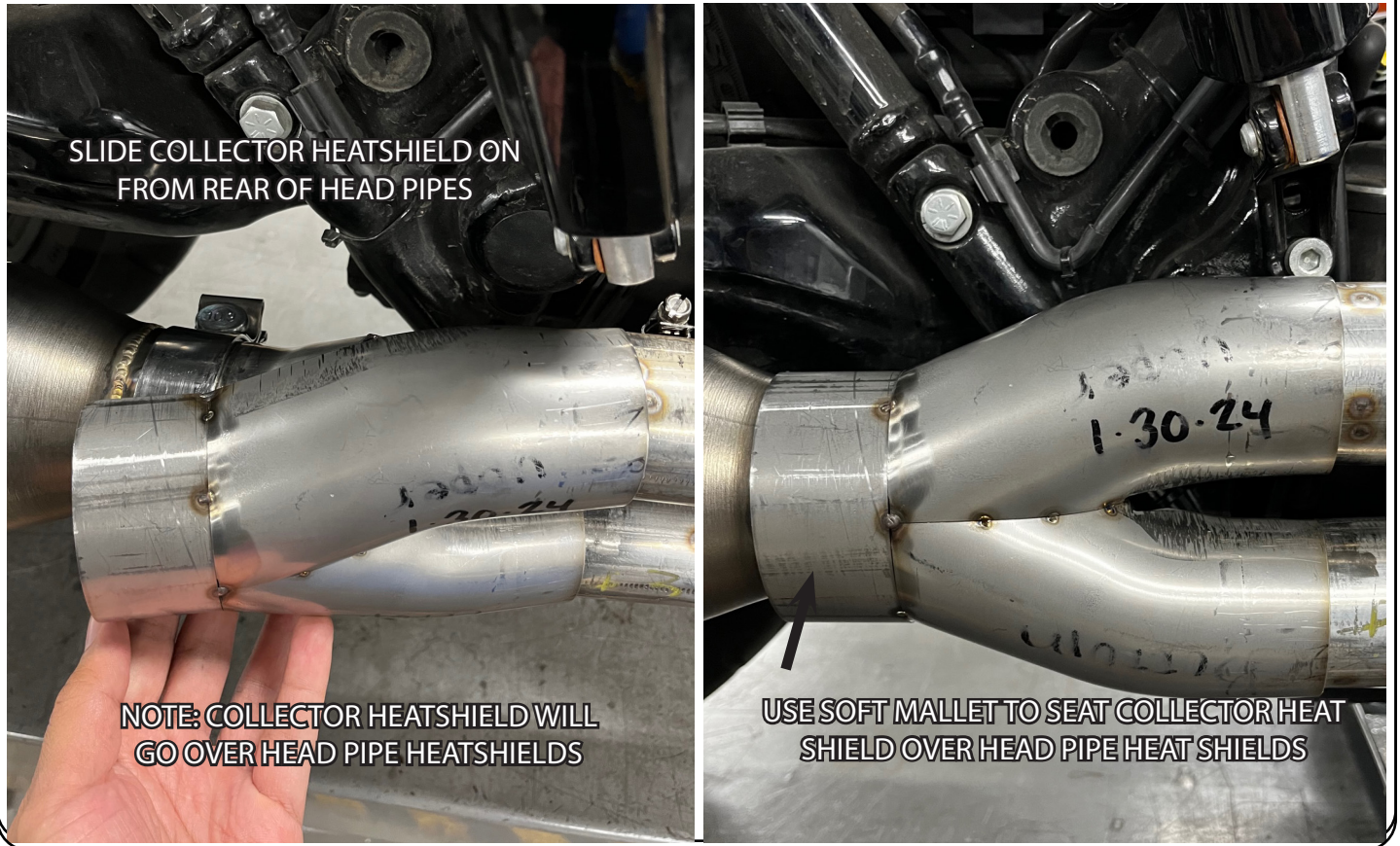

**FIGURE 4**

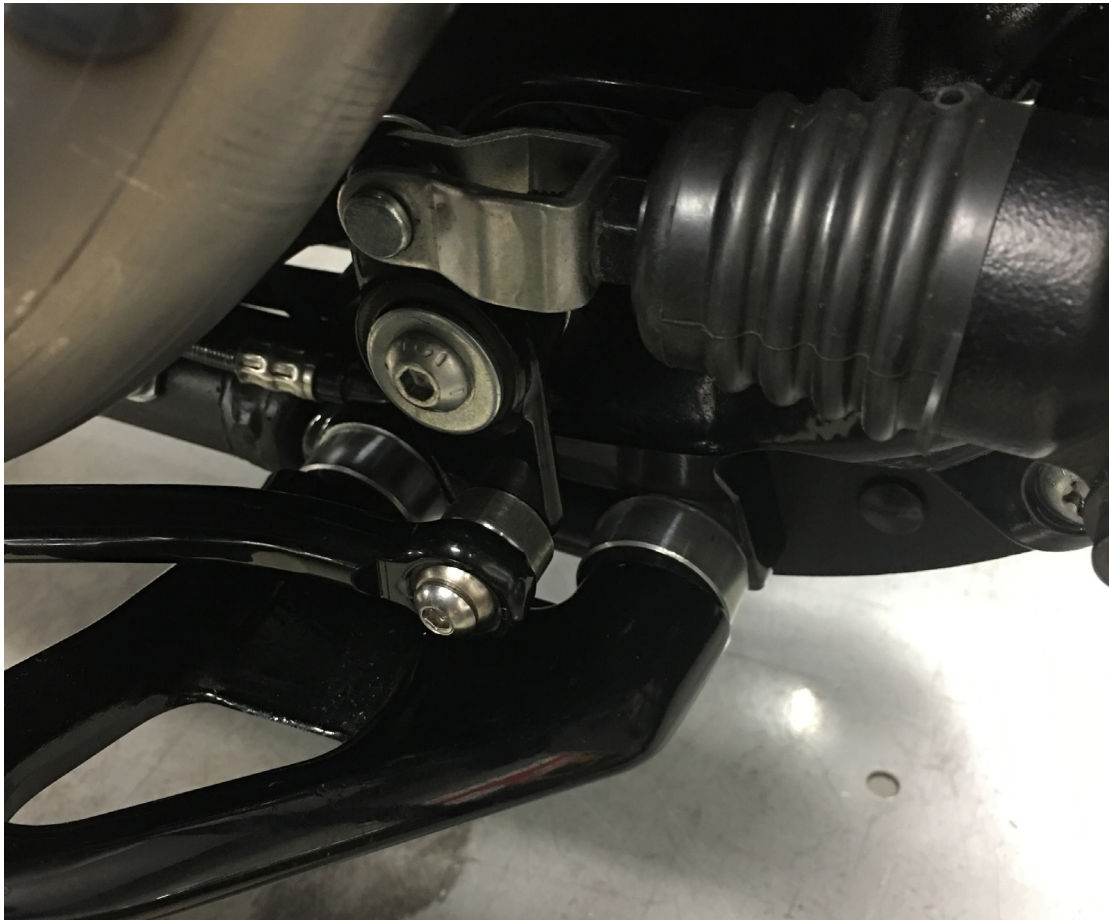

**FIGURE 5**



### **EXHAUST CARE (STAINLESS)**

1. When installing a new set of stainless pipes, make sure your hands are clean and free of oil. After installation, thoroughly clean pipes with a soft cloth and cleaning solvent that will leave no residue (glass cleaner, alcohol, acetone, etc...) before starting the motorcycle.
2. It is considered normal for stainless steel exhaust systems to discolor due to heat.
3. High performance engine tuning utilizing a dyno will likely result in severe discoloration.
4. Avoid long periods of idling as this can cause discoloration. Intake leaks can cause the engine to run lean and overheat and this could lead to discoloration.
5. Make sure there are no exhaust leaks at the junction of the exhaust pipes and cylinder head. We recommend replacing gaskets if they are worn.



Emissions Notice:

In California, in order to meet Air Resources Board emissions requirements, certain aftermarket part applications have been identified as replacements, and others have received ARB Executive Orders. All other emissions related aftermarket parts are for competition use only. A list of replacement parts and EO parts, and corresponding fitment is provided at [vanceandhines.com/california](http://vanceandhines.com/california).

Warranty:

All Vance & Hines products are warranted against defects in material and workmanship for a period of 90 days. This warranty does not cover discoloration or rust. This warranty shall be limited to the repair or replacement of the product, which may be proven defective under normal use. Vance & Hines will not warranty any system that has been abused, misused, improperly installed or modified.

Dealers or distributors are not authorized to make dispositions binding upon Vance & Hines. Vance & Hines will not be responsible for any labor charges incurred in removing or replacing any system under warranty. A return authorization number and a copy of the original purchase invoice must accompany all returns. Parts returned without a return authorization may be refused.

Please Note: Every effort is made for Vance & Hines Exhaust Systems to provide improved cornering clearance. However, due to design and space limitations on some motorcycle models, ground and cornering clearance may not be improved and in some cases may be reduced. Be sure to follow proper installation instructions.

Vance & Hines warrants each Catalytic Exhaust System is designed and manufactured to conform at the time of initial retail purchase with the applicable California Air Resources Board (ARB) regulations for After-market Critical Emission Control Parts on Highway Motorcycles and is free from defects in materials and workmanship which would cause a motorcycle to fail to conform to those regulations for the following warranty periods (as applicable):

(1) If the Catalytic Exhaust System is installed on a highway motorcycle within four years of the date that the highway motorcycle is first acquired by an ultimate purchaser, the warranty period shall be 5 years or 30,000 km (18,641 miles), whichever first occurs, from the date of initial retail sale, or (2) If the Catalytic Exhaust System is installed on a highway motorcycle more than four years of the date that the highway motorcycle is first acquired by an ultimate purchaser, the warranty period will be three years or 15,000 km (9,320 miles), whichever first occurs, from the date of initial retail sale.

**COVERAGE.** The above described warranty periods apply only to emissions-related defects, such as the integrity of the catalytic converter. This warranty does not apply to cosmetic defects and does not apply to any defects resulting from situations described below under "LIMITATIONS." Catalytic Exhaust System with warranted defects shall be repaired or replaced by Vance & Hines, or by a dealer designated by Vance & Hines, at no cost to the owner. Vance & Hines will also be liable for damages to other motorcycle components proximately caused by a failure under warranty of the Catalytic Exhaust System.

**OWNER'S OBLIGATIONS.** The following obligations must be fulfilled by the Catalytic Exhaust System owner to maintain the validity of the emission defects warranty:

a. Owner is responsible for the performance of all emissions-related maintenance prescribed by the vehicle manufacturer. Vance & Hines recommends that you retain all receipts covering maintenance on your motorcycle related to any alleged defect, but Vance & Hines cannot deny warranty solely for the lack of receipts or for your failure to ensure the performance of all scheduled maintenance.

b. Owner is responsible notifying Vance & Hines as soon as a problem exists. Owner may be required to have the motorcycle inspected by a dealer designated by Vance & Hines at the dealer's place of business during customary business hours. Catalytic Exhaust System with warranted defects will be repaired or replaced in a reasonable amount of time, not to exceed 30 days.

c. Owner must present a copy of the proof of initial retail purchase date of both the Catalytic Exhaust System and motorcycle, issued at the time of purchase to Vance & Hines at the time warranty repairs or replacements are performed.

**LIMITATIONS.** This emission defects warranty shall not cover repair or replacement of the Catalytic Exhaust System required as a result of accident, misuse or neglect, repairs improperly performed, use of replacement parts or accessories not conforming to the motorcycle manufacturer's specifications which adversely affect performance and/or durability, alterations or modifications not recommended by the motorcycle manufacturer or Vance & Hines, and/or any motorcycle on which odometer mileage has been changed so that the actual mileage cannot be determined.

**LIMITED LIABILITY.** The liability of Vance & Hines under this emission defects warranty is limited solely to the remedying of defects in materials or workmanship of the Catalytic Exhaust System by Vance & Hines or a third party approved by Vance & Hines at that party's place of business during customary business hours. This warranty does not cover inconvenience or loss of use of the motorcycle, or transportation the Catalytic Exhaust System or the motorcycle on which the system is installed to Vance & Hines or a third party approved by Vance & Hines.

If you have any questions regarding your warranty rights and responsibilities, you should contact Vance & Hines at [info@vanceandhines.com](mailto:info@vanceandhines.com) or (562) 921-7461.

#### NOTICE TO INSTALLER

The California Evaluation Procedures for Aftermarket Critical Emission Control Parts on Highway Motorcycles require that installers of aftermarket critical emissions control parts, such as the Vance & Hines Catalytic Exhaust System, warrant that such parts are installed correctly in accordance with the instructions set forth in this document, and that the installation will not cause the failure of the part to conform to the applicable requirements of the procedures or cause damage to any original part on the highway motorcycle due to incorrect installation. The installation warranty shall be 2

years or 12,000 kilometers (7,456 miles) from the date of the installation of the aftermarket critical emissions control part, whichever occurs first.

Installers and retailers of aftermarket critical emissions control parts, such as Vance & Hines Catalytic Exhaust System, keep documentation regarding the sale and/or installation of such parts, including part number/model, date of sale and/or installation, purchaser name and address, vehicle make, model and vehicle identification number. All such documentation must be maintained for a period of 5 years from the date of sale or installation and be made available upon request by California Air Resources Board staff.

## INSTALLER WARRANTY

Installer warrants that this Vance & Hines Catalytic Exhaust System has been installed correctly, in accordance with the manufacturer's specified instructions, and that the installation will not cause failure of the Supersport 2-1 Catalytic Exhaust System to conform to the applicable requirements of the California Evaluation Procedures for Aftermarket Critical Emission Control Parts on Highway Motorcycles or cause damage to any original part on the highway motorcycle due to incorrect installation. This installation warranty shall be for two years or 12,000 kilometers (7,456 miles) from the date of the installation of the Catalytic Exhaust System, whichever occurs first.

**COVERAGE.** The above described installer's warranty periods apply only to installation-related defects, and not to the function or integrity of the catalytic converter, which is warranted by Vance & Hines. This installer's warranty does not apply to cosmetic defects and does not apply to any defects resulting from situations described below under "LIMITATIONS." Catalytic Exhaust System with warranted defects shall be repaired or replaced by Vance & Hines, or by a dealer designated by Vance & Hines, at no cost to the owner. Vance & Hines will also be liable for damages to other motorcycle components proximately caused by a failure under warranty of the Catalytic Exhaust System.

**LIMITATIONS.** Installer's warranty shall not cover repair or replacement of the Catalytic Exhaust System required as a result of accident, misuse or neglect, repairs improperly performed by someone other than installer, use of replacement parts or accessories not conforming to the motorcycle manufacturer's specifications which adversely affect performance and/or durability, alterations or modifications not recommended by the motorcycle manufacturer or Vance & Hines, and/or any motorcycle on which odometer mileage has been changed so that the actual mileage cannot be determined.

13861 ROSECRANS AVENUE / SANTA FE SPRINGS, CA 90670  
SALES: (562) 921-5388  
TECHNICAL: (562) 926-5291  
FAX: (562) 802-0110

**vanceandhines**  
**.com**