

## INSTALLATION INSTRUCTIONS: 1991- 2009 HARLEY DAVIDSON DYNA TWIN SLASH SLIP-ON'S PART# 46838

Congratulations, you have purchased the finest exhaust system available for your motorcycle. Your Vance & Hines exhaust is designed and crafted for performance, quality, and style. Please follow the instructions below, check exhaust system for missing or damaged parts and if you need any assistance please contact our technical support line (562) 921-7461.

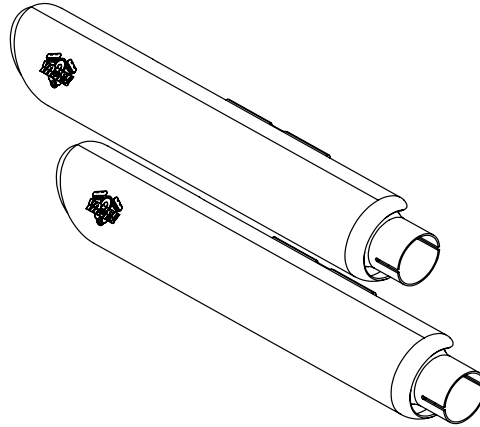

### PARTS LIST

	Part No.	Description	Qty.
1	D743RC	Muffler Casing	2
2	D757HP-S	Black Heat Shield with Badge	1
3	D747HP	Black Heat Shield	1
4	A276HW	1.81" - 2.75" SS Hose Clamp	4

## MUFFLER COMPONENTS

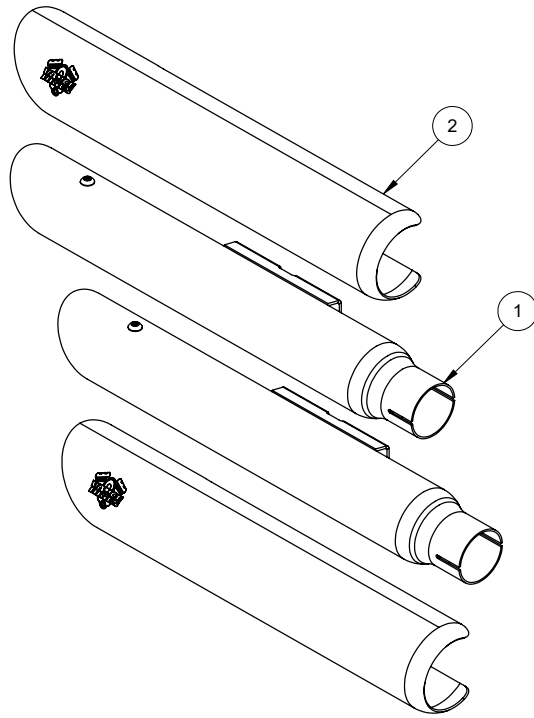

## HARDWARE

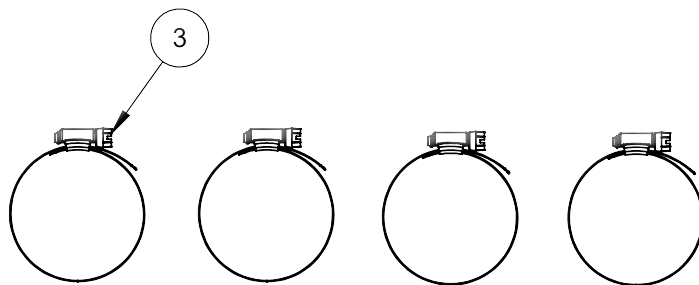

## TOOLS REQUIRED

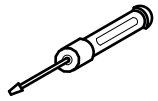

Flat Blade Screwdriver

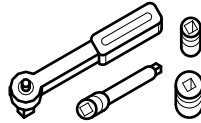

3/8" Ratchet w/ 4" extension  
& 1/2" Standard, 9/16" Deep  
Socket

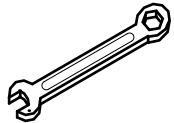

Combination Wrench: 1/2"

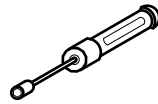

5/16" Nut Driver

## STOCK EXHAUST SYSTEM REMOVAL

1. Before removing the stock exhaust system note orientation particularly of the support bar between the two muffler bodies (Figure 1) and the muffler clamps. If necessary, using tape or another easily removable means, note the orientation on the stock support to ease re-installation.
2. Remove the four 1/2" lock nuts that hold the support bar to the stock mufflers and remove the stock support bar and bolts (set the nuts, bolts, and support bar aside as they will be used later).
3. Using the 9/16" deep socket, loosen the clamps holding the mufflers on to the head pipes. NOTE: May require assistance and the use of penetrating oil.
4. The stock muffler clamps may be re-used. However, Vance & Hines recommends replacing them with new clamps (Vance & Hines part # A335HW-R). If using the stock clamps be sure the T-bolt does not twist out of the groove during tightening. This could allow the clamp to loosen with use.

## VANCE & HINES EXHAUST INSTALLATION

1. Remove the muffler assemblies and heat shields from their protective packaging. Place each heat shield on a non-abrasive surface such as a towel, blanket, or carpet.
2. Carefully lay the muffler assembly into the heat shield and loosely install the hose clamps (supplied) by feeding the tail end of the clamp into the heat shield clips (Figure 2). Note the direction of the clamp screw heads, they must be accessible for adjustment when system is installed (Figure 3).
3. Adjust the heat shield so that the muffler body protrudes beyond the heat shield by .4 inches, and the muffler body and heat shield edges are parallel (Figure 4). Tighten band clamps.
4. Slip a T-bolt clamp over the nose of a muffler assembly. Slide the assembly onto the lower (Front) head pipe until the muffler body makes contact with the stock header heat shield. The clamp must be oriented with the nut accessible from below. Tighten the clamp enough to hold the muffler in place and allow for adjustment later.
5. Repeat step 4 with the upper muffler assembly. The clamp must be oriented with the nut being accessible from the top.
6. Insert the stock 5/16" carriage bolts into the slots in the bracket welded to the muffler body.

7. Install the stock muffler support bar onto the 5/16" bolts and secure it with the stock 1/2" lock nuts but do not tighten fully at this time to allow for muffler alignment. NOTE: Make sure that the support bar is correctly oriented and that the bar ends sit flat against both mufflers; rotate the mufflers if necessary (See Figure 1).
8. Align the mufflers, viewing from the rear of the motorcycle, the mufflers should appear aligned with each other vertically and from the side they should appear parallel with each other and the stock heat shields.
9. Holding the correct alignment, tighten the muffler clamps and support bar locking nuts. NOTE: May require assistance at the time to visually check alignment while you tighten the hardware.
10. **Be sure to verify that all hardware has been tightened before starting your motorcycle.**

### **EXHAUST CARE (BLACK)**

1. When installing a new set of black pipes, make sure your hands are clean and free of oil. After installation, thoroughly clean pipes with warm soapy water and a soft cloth. Dry with a clean towel to remove any residue before starting the motorcycle. Do NOT use anything abrasive to clean the pipes.
2. Avoid long periods of idling as this can cause discoloration.
3. Intake leaks can cause the engine to run lean and overheat, this could lead to discoloration.
4. Make sure there are no exhaust leaks at the junction of the exhaust pipes and cylinder head. We recommend replacing gaskets if they are worn.

FIGURE 1

STOCK SUPPORT BAR ALIGNMENT

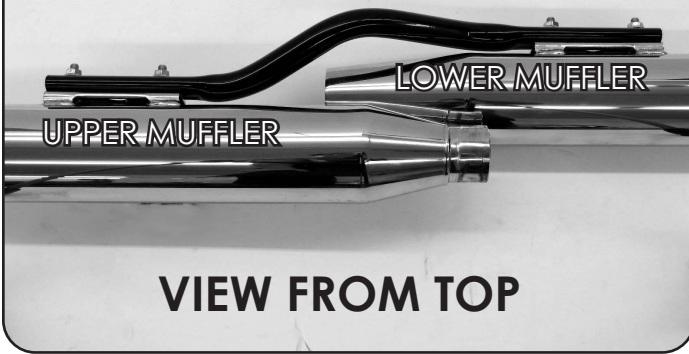

FIGURE 2



FIGURE 3

SCREW HEAD DIRECTION

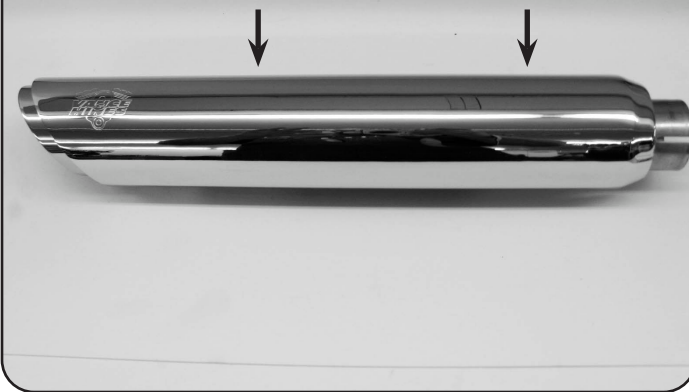

FIGURE 4



Emissions Notice:

In California, in order to meet Air Resources Board emissions requirements, certain aftermarket part applications have been identified as replacements, and others have received ARB Executive Orders. All other emissions related aftermarket parts are for competition use only. A list of replacement parts and EO parts, and corresponding fitment is provided at [vanceandhines.com/california](http://vanceandhines.com/california).

Warranty:

All Vance & Hines products are warranted against defects in material and workmanship for a period of 90 days. This warranty does not cover discoloration or rust. This warranty shall be limited to the repair or replacement of the product, which may be proven defective under normal use. Vance & Hines will not warranty any system that has been abused, misused, improperly installed or modified.

Dealers or distributors are not authorized to make dispositions binding upon Vance & Hines. Vance & Hines will not be responsible for any labor charges incurred in removing or replacing any system under warranty. A return authorization number and a copy of the original purchase invoice must accompany all returns. Parts returned without a return authorization may be refused.



### Connect. Tune. Ride.

From the team that brought you The Fuelpak FP3, the best-selling ECU tuner in the world for Harley-Davidson motorcycles, the Vance & Hines FP4 is the most intuitive tuning tool on the market, giving you the power to control your motorcycle's tune and offers the best-in-industry support from our FP4 technicians, all from your smartphone.

- Download and Flash Maps
- Live Data Viewing
- Autotune Feature for Map Customization

Visit [vanceandhines.com](http://vanceandhines.com) to learn more about FP4.

**Qualified Manufacturer Declared 49-state Federal Emissions Compliant Part.**



13861 ROSECRANS AVENUE / SANTA FE SPRINGS, CA 90670  
SALES: (562) 921-5388  
TECHNICAL: (562) 926-5291  
FAX: (562) 802-0110

**vanceandhines**  
**.com**